

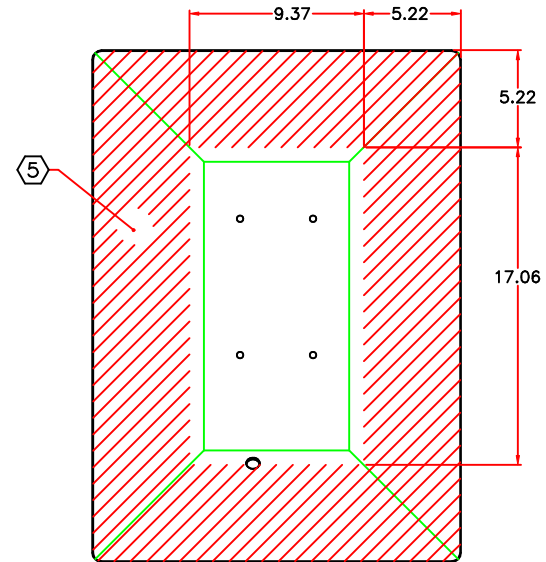

NOTED, UNLESS OTHERWISE SPECIFIED

1. DRAWING CONFORMS TO & INTERPRETATION PER ANSI Y14.5M-82, DIMENSIONING & TOLERANCING
2. REMOVE BURRS & BREAK ALL SHARP EDGES
- ③ MATERIAL: 6061-T6 AL-ALY SHT, .09 THK.
- ④ SURFACE PREP: SHALL CONFORM TO MWS-90001 SECTION 19 & 20 FOR A CLASS 2 SURFACE.
- ⑤ FINISH: CARDINAL T243-GR301 OR EQUIVALENT EXCEPT IN HATCHED AREAS.



DATE	SYM	REVISIONS	BY:
07-31-02	A	ECD# 02-9172	RR
07-3-02	4	RELOCATED .800 HOLE WAS .75, DELETED MATERIAL NOTE 2 WAS 304 SS	RR
06-25-02	3	MATERIAL CHG FROM 304 SST, ADDED NOTES 4,5,& 6	RR
06-20-02	2	MATERIAL CHG FROM 302 SST	RR
06-6-02	1	INITIAL RELEASE PER ECD 02-XXXX	RR

RELEASED BY:	TOLERANCES UNLESS OTHERWISE NOTED: DECIMAL .XX ± .010 .00X ± .005 ANGLE ± 1° MACHINE FINISH 125/		
NEXT ASSEMBLY:	PART NAME:		
SURFACE COATING:	⑤	SHIELD, ISOLATION	
MATERIAL: SEE NOTE	③		
FILE LOCATION:	DRAWING: Name	DATE:	SCALE: NONE
SHEET NO.:	1 OF 1	DRAWING NO.:	REV: A
		ES-9184	